

## HELM INSTRUMENTS

The instruments at the helm tell you what is going on inside the engine. Whenever an engine is running, check the instruments frequently for unusual readings. If a gauge shows a substantial variation from its normal reading, don't take chances. Check for the cause immediately.

When you take delivery, ask your dealer about the normal readings of the gauges. This provides a reference point for the life of the engine. Keep in mind that the reading on some gauges may fluctuate.

**Note:** Your boat may not have all the instruments discussed in this section. The ranges of the gauges may also vary from the readings listed.

## MERCURY® SMARTCRAFT™

Some models come equipped with Mercury® SmartCraft™ digital pilot gauges. Two digital gauges are available, a tachometer and a speedometer. Each gauge will power up when the ignition is turned on. Gauges will stay on as long as the ignition is on. Each Mercury® SmartCraft™ pilot gauge is also equipped with a digital message center. When a problem is detected in the engine, the warning display screens will alert the operator to the potential problem. We suggest you carefully read the SmartCraft™ Operation Manual provided with your Owner's Package to get the best performance from the SmartCraft™ pilot gauges.

### SmartCraft™ Tachometer

Depending on engine type, the Tachometer Digital Display Screen provides the following engine information: engine break-in, engine temperature, oil Psi, trim, RPM, water pressure, battery voltage, engine hours, fuel flow, fuel used and depth.

**Note:** The depth sounder is not to be used for navigation or as device to avoid grounding which may result in boat damage or personal injury (if equipped with a depth sounder).

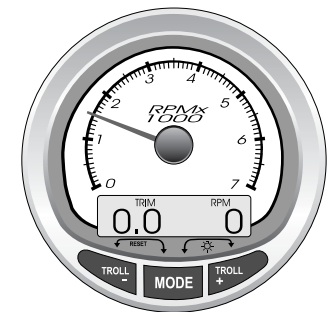

TACHOMETER

### SmartCraft™ Speedometer

Depending on engine type, the Speedometer Digital Display Screen provides the following engine information: speed, fuel used, clock-air/sea temperature, Inst. and avg. fuel economy, trip odometer, fuel tank level, oil tank level if so equipped, trim and RPM synchronizer, fuel range, fuel economy.

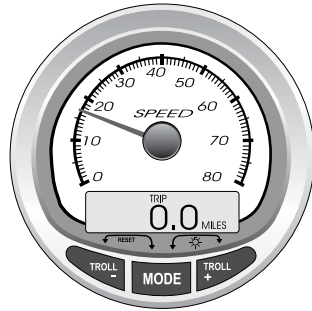

**SPEEDOMETER**

### Tachometer

The tachometer shows engine rotation speed in revolutions per minute (RPMs) under all engine operating conditions. Engine speed is different from boat speed. Weather conditions, boat load, and other factors determine boat speed at a given engine RPM. Consult with your dealer if you require additional information. Do not exceed engine manufacturer's recommendations for maximum RPM.

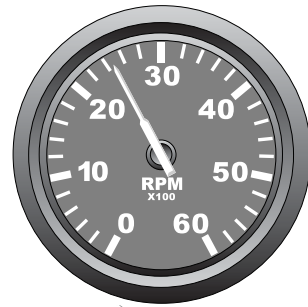

**TACHOMETER**

### Speedometer

The speedometer measures boat speed in miles per hour (MPH). Boat speed, measured in MPH, is different from engine speed, measured in RPMs. The accuracy of this instrument depends on the placement and cleanliness of the pickup tube. Some boats may be equipped with a remote pickup tube which may be tilted up for trailering to prevent damage. It may also be tilted up during operation in shallow water to prevent damage or clogging of the tube with sand or silt. It should be tilted down while underway. The majority of engines are equipped with an integrated speed sensor. Refer to the Engine Owner's Manual for more details.

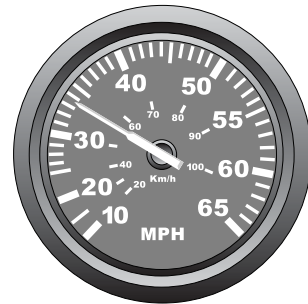

**SPEEDOMETER**

### Fuel Gauge

The fuel gauge displays the approximate amount of fuel in the fuel tank(s). The most accurate reading of the gauge is at idle speed and when the boat is level. While running, the fuel gauge usually reads fuller than the actual level because the bow is higher. Since gauge readings are approximate, it is best to compare them to the hours of use versus known fuel consumption or gallons per hour (gph).

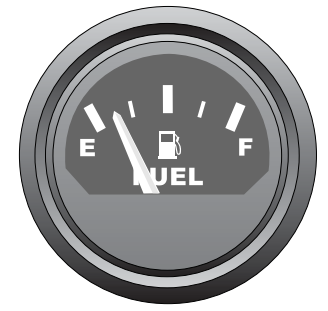

**FUEL GAUGE**

**Note:** A good way to manage the fuel supply is the one-third rule. Use one-third of the fuel to travel to your destination, use one-third to return, and keep one-third in reserve for emergencies.

### Temperature Gauge (Stern drive)

This gauge measures the temperature of the engine cooling system. Check the gauge regularly while the engine is warming up. Marine engines draw sea water, circulate it through the engine, and expel it overboard through the exhaust system. If the temperature gauge shows that the engine is hot, stop the engine immediately and check the cooling system. Refer to the Engine Owner's Manual for instructions and corrective action.

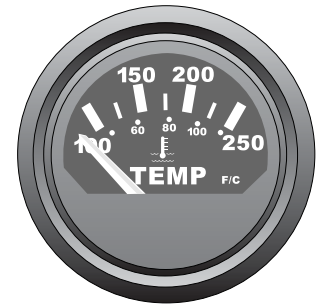

**TEMPERATURE GAUGE**

### Power Trim Gauge

The power trim gauge shows the relative position of the outboard unit. Read the gauge carefully, as it does not show position of unit in degrees. Proper trim should be indicated by bow attitude and engine RPM. For more information see the Engine Owner's Manual.

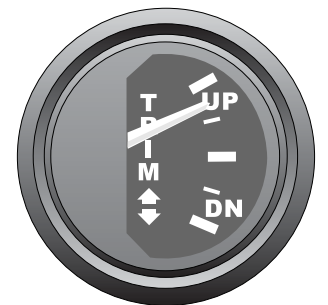

**POWER TRIM GAUGE**

## Voltmeter

The voltmeter measures the condition of the main or cranking battery in DC volts. Normal operating voltage when the engine is running at 1000 RPM or higher is between 12 and 15 volts. If your battery is fully charged, the voltmeter should read in the 11.5 or 12.5 volt range when the ignition is on and the engine is not running. Check your battery and charging system if the voltmeter reads below these normal ratings. An oscillating voltmeter reading may indicate loose belts or loose electrical connections.

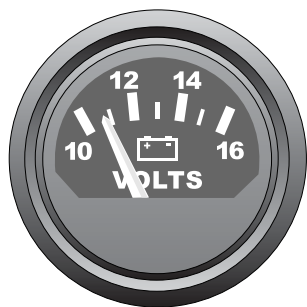

VOLTMETER

## Trolling Motor Battery Power Level Gauge

The battery power level gauge located on the bow panel of some types of boats provides you with the remaining voltage of the trolling motor deep cycle battery. Check the gauge on a regular basis when you are using your trolling motor. If the battery voltage is low and your boat is equipped with a battery charger, turn the charger on whenever your boat is connected to shore power or once the boat is out of water and is on a trailer. Otherwise, remove your battery from the compartment and charge it with a battery charger.

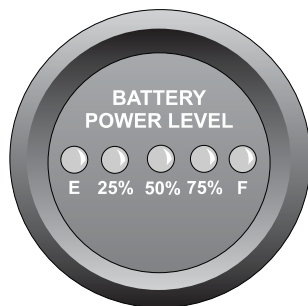

TROLLING MOTOR BATTERY POWER LEVEL GAUGE

**Note:** the alternator for the main engine does not charge the trolling motor battery.

## Oil Pressure Gauge (Stern drive)

The oil pressure gauge provides you with the pressure, in BAR or PSI, of the engine oil. If you see any irregularity in the pressure level of your boat's main engine, refer to your Engine Owner's Manual.

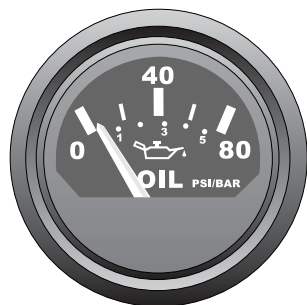

OIL PRESSURE GAUGE

## Depth Sounder and Fish Finder (not shown)

Some boats are equipped with a fish finder that helps you to locate fish and provides the depth of the water. The fish finder should not be used as a navigation device. We strongly recommend that you read the Installation and Operation Instructions Manual provided with your boat literature for a good understanding and maximum usage of your fish finder.

## ENGINE THROTTLE/SHIFT CONTROL

**Note:** See your Engine Owner's Manual for operating information for tiller mounted engines or kicker motor controls.

The Engine Owner's Manual included with your Owner's Packet has detailed information about the throttle/shift control installed on your boat. The control serves two purposes: (1) it regulates the engine speed and (2) it acts as a gear shift lever to control the rotation of the propeller. When the handle is in the center, the gearshift is in neutral. As you move the handle forward and backward, you should feel the handle drop into a detent when the handle moves into the NEUTRAL position. The engine will not start unless the control is in NEUTRAL. Figure 6-1 shows a typical control.

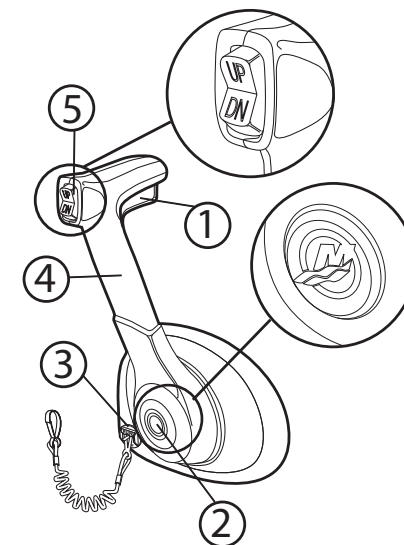

FIGURE 6-1 TYPICAL THROTTLE SHIFT CONTROL

- 1. Neutral Lock Button**-Prevents accidental shift and throttle engagement. The red neutral lock button must be squeezed upwards to move the control handle out of NEUTRAL.
- 2. Throttle-Only Button**-Allows engine throttle advancement without shifting the engine. This is done by disengaging the shift mechanism from the control handle. The throttle-only button can be depressed only when the remote control handle is in the NEUTRAL position, and should only be used to assist in starting the engine.
- 3. Lanyard Stopswitch**-Turns the ignition OFF whenever the operator (when attached to the lanyard) moves far enough away from the operator's position to activate the switch.

4. **Control Handle**-Operation of the shift and throttle are controlled by the movement of the control handle. Squeeze the neutral lock button upwards, then push the control handle forward from NEUTRAL with a firm motion to the first detent for FORWARD gear. Continue pushing forward to increase speed. Pull the control handle back from NEUTRAL with a firm motion to the first detent for REVERSE gear and continue pushing back to increase speed.
5. **Trim Tilt Button (if so equipped)**- Some controls may have a trim control switch which you may use to adjust the position of the outboard. Pressing the switch in the UP position moves the outboard out and away from the transom. Pressing the switch in the DOWN position moves the outboard in closer to the transom. The switch returns to its center neutral position when released. Some controls may also be equipped with a trim/tilt switch. This switch works in the same way as the trim switch, the only difference being that pressing the switch in the UP position moves the stern unit near water level. By applying a stronger pressure on the switch in the UP position, the stern drive is raised to the upper position suitable for trailering, beaching or launching.

For more information, please review your Engine Owner's Manual.

**IMPORTANT:** Allow the engine to warm up before engaging the shift control. Monitor all instruments while engine is idling during warmup. See the engine manufacturer's specifications for proper operating ranges.

Moving the throttle forward or backward increases engine speed and increases boat speed if the engine is in either forward or reverse gear. The further the throttle is moved, the faster the engine runs.

*Rapid acceleration in reverse may cause a wake that could rise above the transom and flood the boat.*

When maneuvering at low speeds, reversing the direction of propeller rotation causes a braking action which helps stop the boat.

**Note:** When reversing direction at an engine speed over 1000 RPM, hesitate in neutral long enough to let the propeller slow its turning so as to avoid damage to the shifting mechanism.

## SWITCHES

**Note:** Not all models will have all switches.

### Bilge Pumps

Your boat may be equipped with a manual and/or an automatic bilge pump.



The manual bilge pump switch may be used to turn the pump on or off. Only run the pump until it no longer expels water, do not run it dry.



The automatic bilge pump switch may be used to turn on the pump, instead of waiting for the automatic float switch in the bilge to activate the pump. Be sure to return the switch to the automatic mode when the pump no longer expels water. As long as the battery has a charge and the switch is in the automatic mode, the pump will turn on whenever bilge water sets off the automatic float switch.



### Bilge Blower (Stern drive models only)

Use the bilge blower switch to force gasoline fumes out of the engine compartment before starting the engine. Run the blower at least four minutes prior to starting the engine, and whenever the boat is operated at less than cruising speed. Do not operate the blower while fueling the boat. Keep all engine compartment vents free of obstructions to ensure proper ventilation.



## ⚠ WARNING

**Explosion Hazard!** Gasoline vapors are explosive. Operate bilge blower for at least four minutes before starting engine to eliminate gasoline fumes in the bilge. Listen to the blower in the engine compartment to verify it is operating. Check engine compartment for fumes or gasoline leaks before starting engine. Do not start engine if gasoline or fumes are present.

### Navigation Lights

This three-position switch activates the bow and stern running navigation lights. This switch may be used as well to turn on the white stern light while anchored.

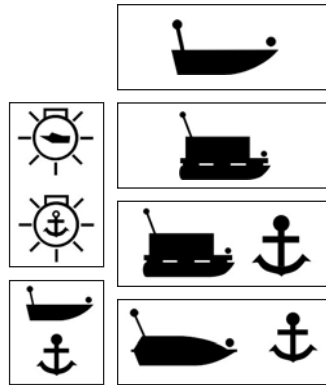

### Horn

This momentary switch activates the boat's horn. Push or turn the switch and hold it to sound the horn. Release the switch to silence the horn.

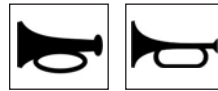

### Radio

The radio switch gives power to your radio. Pressing the switch on the green button will give power to the radio. To avoid battery drainage, we recommend turning the switch off while you are not using the radio, if so equipped.



### Accessory

This switch may be used to control any aftermarket equipment that may be added to the boat.



### Courtesy Light

This switch activates the boat's courtesy lights. The three-position version of this switch also controls the boat's interior lights.

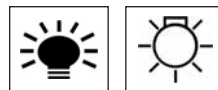

### Livewell Filling Pump

This switch controls the livewell filling pump, and may be combined with the livewell recirculating pump switch.

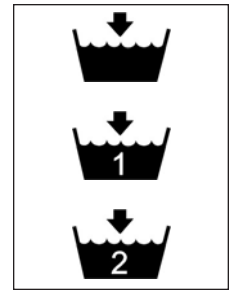

### Outboard Tilt/Trim

Use this switch to tilt the outboard motor when in shallow water. Push and hold the switch until the motor is tilted to the desired position, and then release the switch. In the case of a sterndrive unit, the switch is also equipped with a trim function that is activated by a double clicking up on the switch. This allows you to raise the sterndrive out of the water.

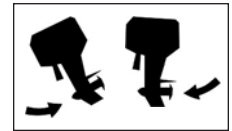

### Battery Check Switch

This switch enables you to check the remaining voltage in either battery.

**Note:** All switches should be in the off position when not in use. Bilge and livewell system pumps may be damaged if allowed to run dry.

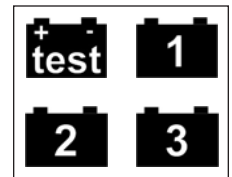

## Circuit Breakers and Fuses

Your boat's electric circuits may be equipped with breakers and/or fuses, depending on boat model. The following table lists circuit breakers and fuses that may be found on your boat. Be sure to use the same size breaker or fuse if replacement is needed.

Switch	Fuse AMP	Fuse Type
Accessory	15	AGC
Battery charger	15	AGC
Bilge Pump	2	AGC
Blower	4	AGC
Courtesy Lights	5	AGC
Docking Lights	10	AGC
Electric motor	40	ATC
Horn	10	AGC
Large Capacity Bilge Pump	4	AGC
Livewell Filling & Oxygenating System	2	AGC
Main Harness	20 or 30	ATC
Navigation Lights	5	AGC
Radio	15	ATC
12V Receptacle	15	ATC
Refrigerator	10	ATC
Shower pump	5	ATC

AGC: Glass type fuse  
ATC: Blade type fuses

## COLOR CODE FOR DASH PANEL WIRING

Color	Color Code	Description
Red	R	Main power feed
Black	B	Ground
Gray	G	Rear navigation light
Gray/White	G/W	Front navigation light
Pink	P	Fuel level gauge
Dark Green	DG	Bonding System
Brown	C	Bilge Pump
Brown/Orange	C/O	Front livewell filling system
Brown/Red	C/R	Rear livewell filling system
Brown/White	C/W	Front livewell oxygenator
Brown/Yellow	C/Y	Rear livewell oxygenator
Blue/White	DB/W	Courtesy light
Dark blue	DB	Interior Light
Orange/White	O/W	Horn
Red/White	R/W	Sonar
Red/Yellow	R/Y	Radio
Yellow	Y	Blower I/O
Gray *	G	Tachometer
Tan *	T	Water temperature gauge
Light Blue *	LB	Oil pressure gauge
Yellow/Red *	Y/R	Starting circuit
Violet *	V	Instrumentation power feed
Orange	O	Accessory
Red/Brown	R/C	Automatic bilge pump sensor
Brown/White *	C/W	Trim gauge
Brown/Black	C/B	Automatic bilge pump
Blue/Red	DB/R	Docking lights (Vacanza)
Red/Gray	R/G	12 Volts Receptacle

\* Color code of Mercury® engine system wiring