

This chapter discusses major systems or components on your boat. Information about boat controls is in Chapter 6. Equipment discussed in this chapter is standard or optional on some models and not available on others. See your dealer for more information.

ENGINES

Your boat may be available with a range of engine options. In your Owner's Packet is an Owner's Manual for the engine. Refer to that manual for information about engine care and maintenance.

Affixed to your boat is a capacity plate that states the maximum size engine that can be used on your boat. Do not overpower your boat.

Keep your engine well tuned to decrease exhaust hydrocarbon emissions that pollute the air and water.

Your dealer employs factory trained technicians certified to service the engine. If you choose to do so, you can handle basic servicing such as checking engine oil. But with today's ever-advancing engine technology, these technicians have the tools and the expertise required for efficient and safe engine service.

WARNING

Do not attempt to maintain or adjust an engine while it is running. Failure to shut off the engine for maintenance or adjustment can result in serious injury or death.

FUEL SYSTEM

The fuel system is designed to prevent fire and explosion and to provide a continuous flow of clean fuel to the engine. It meets or exceeds the applicable requirements of the U.S. Coast Guard at the time of manufacture. The system is also certified by the National Marine Manufacturers Association (NMMA) and the Canadian D.O.T. Every fuel tank must pass rigid tests and inspections by the tank manufacturer.

Before you take delivery, check that your dealer has completed a full inspection of the entire fuel system. You should also inspect the entire system at least once a year.

WARNING

Fire and Explosion Hazard! Leaking gasoline and fuel vapors can burst into flames or explode. Inspect fuel system regularly for leaks, deterioration, and corrosion. Replace defective parts before starting engine.

- **Gas Deck Fill:** If your boat has a built in gas tank, it is equipped with a deck fill plate labeled GAS or GASOLINE. Be sure to use the proper grade fuel as specified in the engine Owner's Manual. See Chapter 7.2 for fueling instructions and recommendations.
- **Gas Tank Vent:** As the engine draws down fuel in the tank, air enters the tank through the vent to prevent a vacuum from forming inside the tank. While you are filling the tank, gasoline entering the tank pushes air in the tank out through the vent. Be careful when filling the tank, otherwise gas will be ejected through the vent when the tank is full or nearly full.
- **Fuel Tank:** The internal fuel tank fittings are accessible through the engine compartment or under removable deck plates. The tank is equipped with a gas fill line, gas vent line, sending unit, and engine fuel pickup.

WARNING

Fire or Explosion Hazard! Ignition and fuel system parts are designed and manufactured to comply with U.S. Coast Guard and Canadian D.O.T. requirements to minimize risks of fire or explosion. **Never substitute automotive parts for marine parts.** Automotive parts do not provide the necessary ignition spark protection.

PROPELLER

The selection of the correct propeller and its condition are the most important items for peak boat performance. The propeller's diameter and pitch have been matched to the engine for trouble free operation and maximum performance (Figure 5-1). See your engine Owner's Manual for propeller removal and replacement procedures.

All models should be "propped" to be in the upper half of the maximum RPM range with the boat lightly loaded and the outboard trimmed up to maximum. This configuration allows the engine to operate within the recommended RPM range with a heavy load.

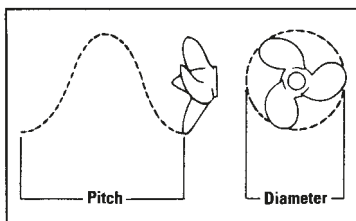

FIGURE 5-1 PROPELLER MEASUREMENTS

If fuel consumption is higher than normal or the handling characteristics have changed, the propeller may be damaged. A damaged or unbalanced propeller can cause excessive vibration or increased noise. If you notice either condition, stop the engine and check the propeller for nicks, cracks, pitting, distortion, or other damage.

Note: Never run with a damaged propeller. You can damage the engine or drive unit. Keep a spare propeller on board. You can continue your excursion without spoiling your day.

If the propeller is damaged, change it. Detailed procedures are in the engine manual. Otherwise, return to port slowly to prevent further drive and engine damage from an out-of-balance condition. Watch the temperature gauge to make sure the engine does not overheat.

Cavitation

Cavitation is the formation of air bubbles along the surface of the propeller. Typical causes of cavitation are a damaged propeller, the outboard trimmed out too far, or a hull projection in front of the engine. Recondition or replace damaged propellers.

Ventilation

Ventilation is the formation of a void around the propeller, usually on entering or leaving a sharp turn (Figure 5-2). Without water to turn in, the propeller runs free and the boat nearly stops moving forward until the propeller finds water to turn in again. When ventilation occurs, throttle back immediately. If ventilation continues when you resume

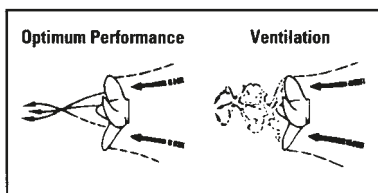

FIGURE 5-2 PROPELLER VENTILATION

speed, you may have to adjust engine trim or the load.

STEERING SYSTEM

Note: The following information refers to the steering system on boats with a helm station. If your boat is not so equipped, see your engine Owner's Manual for information on tiller steering.

Your boat is equipped with either a hydraulic steering system or a mechanical cable system with in some cases a no-feedback system. The hydraulic steering system is comprised of the helm pump and reservoir, hydraulic hoses, and the hydraulic cylinder. The helm assembly acts as a pump to move the oil through the system. In many respects this type of steering is similar to the mechanical system. Instead of activating a cable, turning of the helm causes fluid in the hydraulic hoses to flow and activate the hydraulic cylinder to turn the outboard motor.

If your boat is powered by an inboard engine, it comes equipped with a power steering system. The power steering system is very similar to the hydraulic steering system. The only difference is that with the power steering system, when turning the steering wheel, the power steering pump will be circulating the fluid in the hydraulic system to turn the sterndrive.

NOTICE

If equipped with the hydraulic system, a slight clicking sound may be heard as the wheel is turned. This sound is the opening and closing of the valves in the helm unit; this is normal.

In the mechanized system, a rotary drum or rack and pinion assembly is mounted under the dash behind the steering wheel with a one-piece cable running through the boat to the engine. At the transom, the cable turns and is connected to the engine or outdrive. With the no-feedback system it is normal to feel a certain restriction when you turn the steering wheel.

It is important that you get the "feel" of your boat's steering system. Turn the steering wheel from full left to full right, and make sure the motor steering arm is turning accordingly. The system should operate freely and smoothly. The cable end and its fittings should be kept clear of fuel line, control cables, electrical wiring, or onboard gear when the motor is moved through its full steering cycle in both running and full tilt positions.

All fittings and cables should be inspected for corrosion or damage and

replaced if necessary. Check for the presence of the original self-locking nuts that are used to fasten the “steering link rod” or “drag link” between the steering cable(s) and the engine. These nuts must never be replaced by common or non-self-locking nuts, which can vibrate off. Also, the steering wheel should be inspected for looseness and tightened, if necessary. Replace the steering wheel if there are any cracks around hub or base of spokes.

Steering or propeller torque can be present in any drive system. In some systems, it is more noticeable than in others.

Note: See steering manufacturer’s recommendations for cleaning, lubrication, and maintenance of the steering system.

Note: The steering system should be inspected by a qualified mechanic at regular service intervals.

WARNING

Steering effort can vary significantly with engine acceleration, steering angle, trim angle, and sea condition. Whenever possible, it is best to trim your outboard to generate minimum steering effort. Under all circumstances, the boat operator should keep at least one hand on the steering wheel.

For additional information refer to the “Getting Underway” section of this manual.

LIVWELL SYSTEM

The livewell system on your boat is designed to supply the water and oxygen needed for the survival of your catch. We encourage the careful handling of all fish that you catch, keeping them alive in the livewell. Consider the live release of any fish that you do not care to eat or mount as a trophy.

Some livewell systems come equipped with a two position switch that controls the oxygenation of the livewell water. Place the livewell switch in “MAN” position for a continuous oxygenation or “AUTO” position for intermittent oxygenation.

Some livewell systems are equipped with a second pump that will recirculate the water in the livewell. A three position switch controls both the livewell filling pump and the recirculating pump. Use the recirculating pump when in brakish water, while running at cruising

speed, or while your boat is on the trailer and you want to keep your catch alive. The three livewell systems available are the following : Pro Flo™ Plus, Pro Flo™ and Sport Flo™.

PRO FLO™ PLUS LIVEWELL SYSTEM

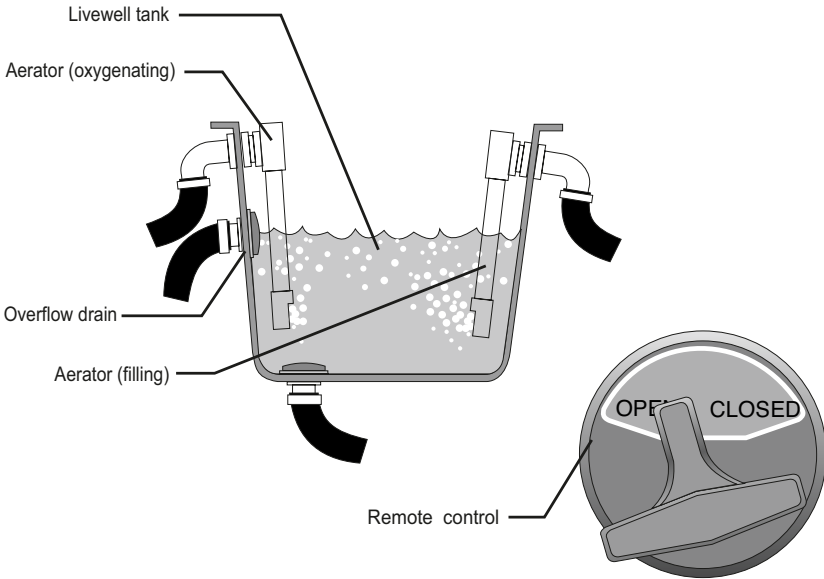

Filling up

- Place the remote control in the "CLOSED" position.
- Start the livewell filling pump using the three (3) position livewell switch. Place the switch in "MAN" (manual) position. The water will increase until it has reached the overflow drain.
- Turn off the livewell pump once the livewell is full. Occasional use of the pump will keep the water fresh.
- Note : You can fill the livewell when the boat is in the water and is stopped or moving at less than cruising speed.

Note: If the livewell pump doesn't activate, put the boat in reverse for a few seconds and this will fill and activate the pump.

Note: Running the pump continuously may drain your boat's battery.

Oxygenation

- Place the remote control in the "CLOSED" position.

- Turn the oxygenation pump using the three (3) position livewell switch. Place the switch in the "AUTO" (automatic timer) position for intermittent oxygenation, if so equipped.
- This system allows continuous recirculation while running, docked or trailering.

Note: Occasional use of the livewell filling pump will keep the water fresh.

Draining

- Turn off the pump and place the remote control in the "OPEN" position.
- When the livewell is empty, place the remote control in the "CLOSED" position to prevent water entering the livewell.

PRO FLO™ LIVEWELL SYSTEM

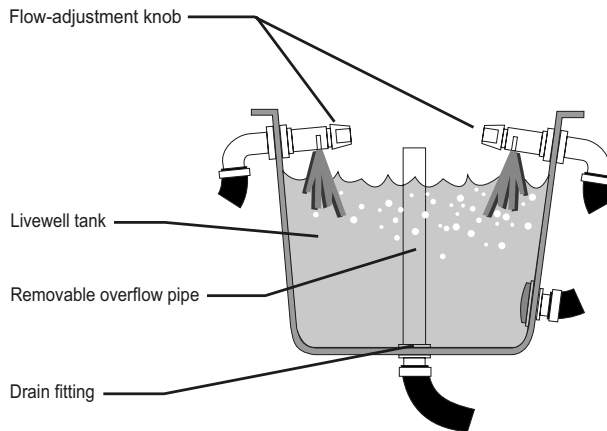

Filling up

- Install the overflow pipe in the drain fitting inside the livewell
- Open the flow adjustment knob in the livewell by turning it counter-clockwise
- Start the livewell filling pump using the three (3) position livewell switch. Place the switch in "MAN" (manual) position. The water will rise in the livewell until it reaches the top of the overflow pipe.
- Use the flow adjustment knob to control the aerator spray.

- Turn off the livewell filling pump once the livewell is full. Occasional use of the pump will keep the water fresh.

Note: you can fill the livewell when the boat is in the water and is stopped or moving at less than cruising speed.

Note: If the livewell pump doesn't activate, put the boat in reverse for a few seconds and this will fill and activate the pump.

Note: Running the pump continuously may drain your boat's battery.

Oxygenation

- Open the flow adjustment knob in the livewell by turning it counter-clockwise
- Start the oxygenation pump using the three (3) position livewell switch. Place the switch in "AUTO" position (automatic timer) for intermittent oxygenation, if so equipped.
- Use the flow adjustment knob to control the aerator spray.
- This system allows continuous recirculation while running, docked or trailering.

Note: Occasional use of the livewell filling pump will keep water fresh.

Draining

- To drain the livewell, stop the pump and remove the overflow pipe.

SPORT FLO™ LIVEWELL SYSTEM

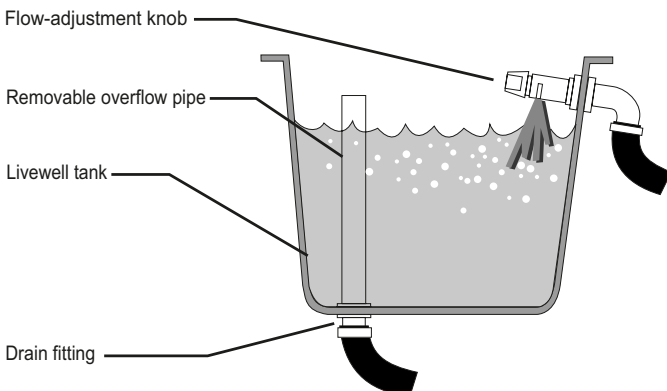

Livewell filling up & oxygenation

- Install the overflow pipe in the drain fitting inside the livewell.
- Open the flow adjustment knob in the livewell by turning it counter-clockwise
- Start the livewell filling pump using the two (2) position livewell switch. The water will rise in the livewell until it reaches the top of the overflow pipe.
- Use the flow adjustment knob to control the aerator spray.
- Turn off the livewell filling pump once the livewell is full. Occasional use of the pump will keep the water fresh.

Note: You can fill the livewell when the boat is in the water and is stopped or moving at less than cruising speed.

Note: If the livewell pump doesn't activate, put the boat in reverse for a few seconds and this will fill and activate the pump.

Note: Running the pump continuously may drain your boat's battery.

Draining

- To drain the livewell, stop the pump and remove the overflow pipe.

General Livewell Plumbing Information

The plumbing system for your livewell consists of several pumps, hoses, fittings, and clamps. While the plumbing system is designed to be leak free, it is the owner's responsibility to frequently check the system's components for leaks, cracks, and worn components. In the event a leak should develop, contact your dealer immediately.

SEAT SETTINGS

Your boat comes equipped with different models of pedestal seats. The instructions below will help you adjust your seats for better comfort or diverse usage. Your seat may not be equipped with all the adjustments mentioned below.

1. If your seat is folded, press the button (A) located on the left hand side of the seat base to open it.
2. To remove the seat from the seat post, lift up the swivel (B) located on the

right hand side underneath the seat base and pull.

3. To remove the seat post from the floor base, press the locking device (C) located at the bottom of the seat post, twist the seat post and pull it up.
4. To turn your seat around, lift up the swivel (B) located on the right hand side underneath the seat base and move your seat clockwise or counter clockwise. Keep in mind that if your seat is not on its initial position, the locking device is not locked in.
5. To slide your seat forward or backward, lift up the swivel (D) located on the front part underneath your seat base and push or pull your seat.
6. To incline the back of your captain seat, if your boat is so equipped, lift up the swivel located on the left hand side of the seat base.

Note: For security purposes and for better driving visibility, we strongly recommend you remove the seat post and to fold down all bow seats when cruising above idle speed.

BILGE

The deepest part of the hull, under the floor, is the bilge. Water may accumulate in the aft portion of the bilge. Be sure to keep the bilge area free of debris so that water can drain through the stringers and bulkheads to the bilge pump area. It is normal to have a small amount of water in the bilge. If you should notice fuel or oil in the bilge, check for leaks and correct immediately. Do not pump fuel or oil overboard, as this act of pollution is a violation of federal law. Clean up fuel and oil and properly dispose of on shore. Oil stains can be removed by using a bilge cleaner available from your dealer. Do not use flammable solvents to clean the bilge.

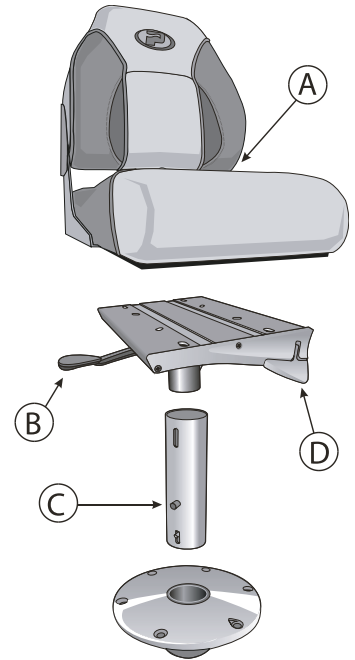

BILGE PUMP

Your boat may be equipped with an electric bilge pump, and may have an automatic float switch. Rising water activates a float switch to start the bilge pump. When the water is pumped out, the pump shuts off automatically.

Note: Electrically operated bilge pumps can fail. There is no substitute for checking the bilge frequently, especially during periods of heavy rain, high seas, or storm conditions. Most models of bilge pumps are equipped with an easy removal pump system that allows you to pull out the pump for easy inspection and servicing. Inspect the bilge pump system on a regular basis and clean it if necessary.

If for some reason the pump fails to start, check the fuse and wiring connections. If the pump motor runs but no water is discharged, it may be clogged. Keep the area around the switch and the pump free of debris. If there is no visible debris clogging the pump or blocking the float switch and water is still not being removed, inspect the discharge hose for kinks or obstruction.

If oil is spilled in the bilge, do not run the pump. Keep the oil from spreading in the bilge and properly dispose of the oil on shore. Your dealer can help you select products you can use to soak up the oil and give you advice about methods of disposal.

The bilge pumps on some models may not have automatic float switches. You must check the water level in the bilge and, if necessary, operate the pump manually using the on-off switch at the helm. Check with your dealer if you have any questions.

SHOWER

Your boat may be equipped with a stern shower. Before using the shower, fill the potable water tank through the filling cap. Turn the shower water pump on using the on-off switch located in the shower cabinet. A red light appears when the pump is running. Activate the shower using the shower head valve. When finished using the shower, shut off the pump using the on-off switch. To prevent battery shortage, the shower pump must be turned off whenever it is not in use (red light must be off).

TROUBLESHOOTING

Following are basic troubleshooting procedures. Always refer to the manufacturer's manual for detailed troubleshooting information.